

Point load

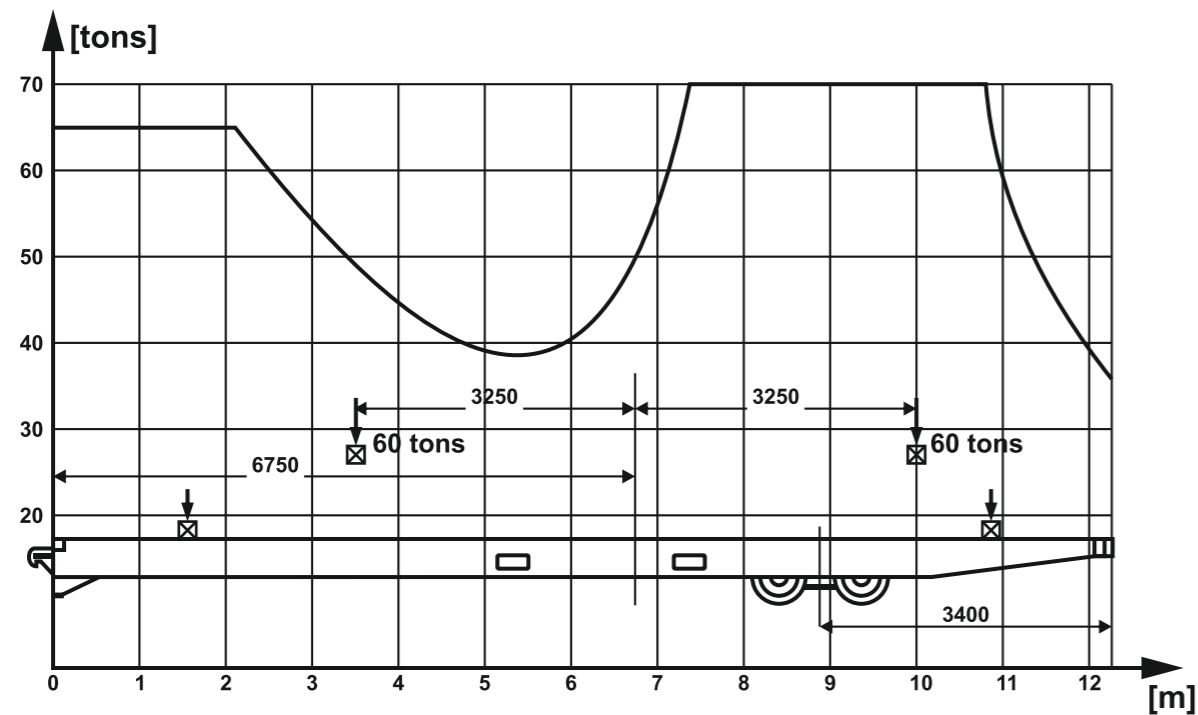

Point loads on the platform to be placed or transferred using transversal supports to the longitudinal beams

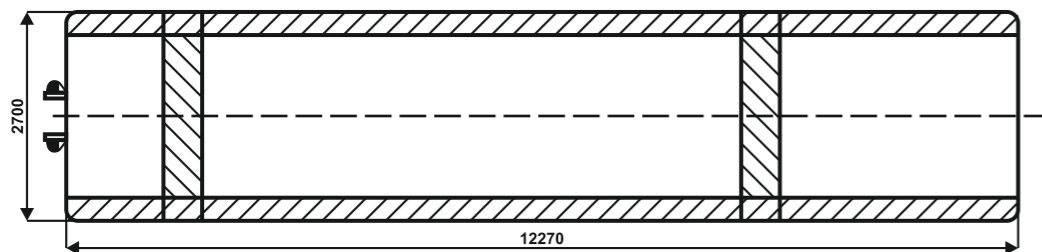

Loading instruction

- 1) Identify loads center of gravity
- 2) Calculate the loads, coming to the Rolltrailer platform acc to below scheme

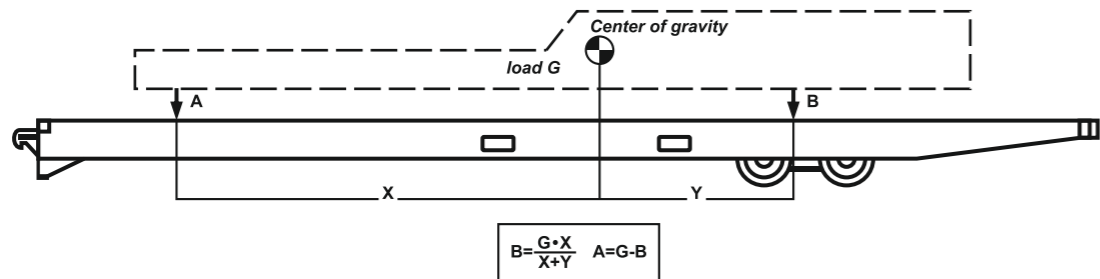

- 3) Make sure, load center of gravity is in the determined area
- 4) Loads A and B shall not exceed the limit line in above diagram

Distributed load

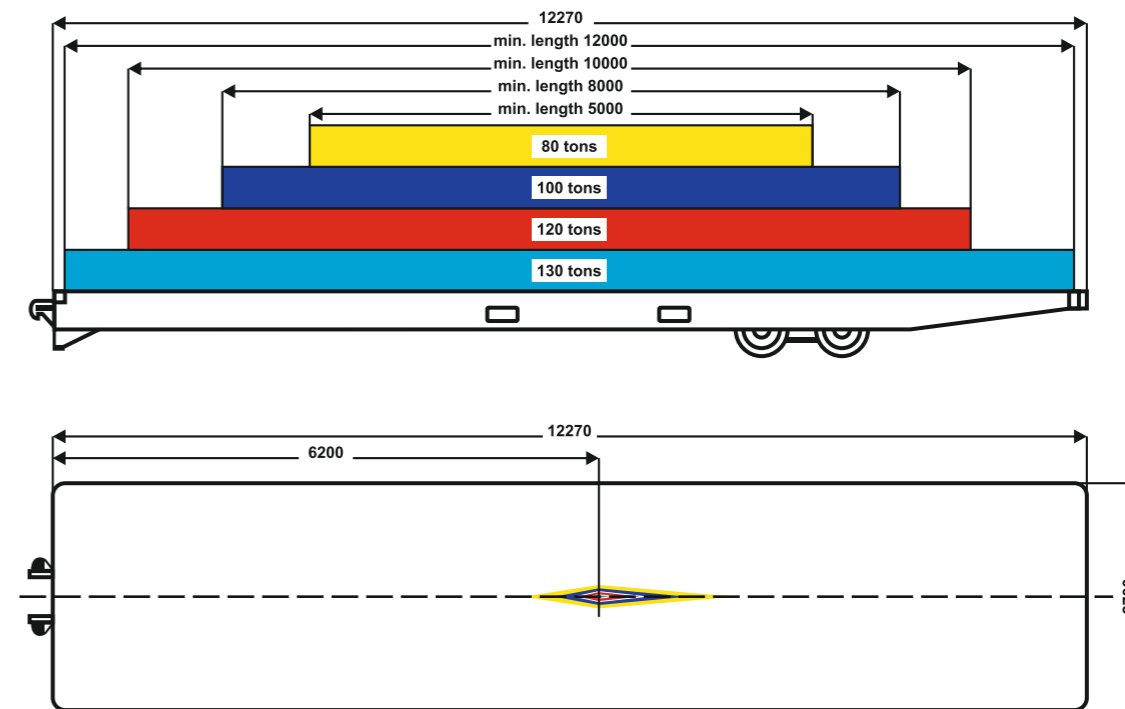

Load center of gravity must be within the areas, corresponding to the load

